



METER DATA MANAGEMENT V 2.2.0

4.2.1.1 MDM.Upload Device Measurements

Creation Date: May 23, 2011

Last Updated: April 13, 2020

ORACLE®

Copyright © 2017, Oracle. All rights reserved.

This document is provided for information purposes only and the contents hereof are subject to change without notice. This document is not warranted to be error-free, nor subject to any other warranties or conditions, whether expressed orally or implied in law, including implied warranties and conditions of merchantability or fitness for a particular purpose. We specifically disclaim any liability with respect to this document and no contractual obligations are formed either directly or indirectly by this document. This document may not be reproduced or transmitted in any form or by any means, electronic or mechanical, for any purpose, without our prior written permission. Oracle, JD Edwards, PeopleSoft, and Siebel are registered trademarks of Oracle Corporation and/or its affiliates. Other names may be trademarks of their respective owners.

Contents

BRIEF DESCRIPTION	5
BUSINESS PROCESS MODEL PAGE 1	6
BUSINESS PROCESS MODEL PAGE 2	7
BUSINESS PROCESS MODEL PAGE 3	8
BUSINESS PROCESS MODEL PAGE 4	9
BUSINESS PROCESS MODEL PAGE 5	10
BUSINESS PROCESS MODEL PAGE 6	11
DETAIL BUSINESS PROCESS MODEL DESCRIPTION.....	12
TEST DOCUMENTATION RELATED TO THE CURRENT PROCESS.....	36
DOCUMENT CONTROL	37
ATTACHMENTS	38
<i>Dictionary</i>	38
<i>IMD Seeder Lifecycle</i>	38
<i>Initial Load IMD Interval Lifecycle</i>	38
<i>Initial Load IMD Scalar Lifecycle</i>	38
<i>Manual IMD Interval Lifecycle</i>	38
<i>Manual IMD Scalar Lifecycle</i>	39
<i>Measuring Component Portal</i>	39
<i>Device Configuration Portal - Incoming Data Shift</i>	39
<i>Review Pending State IMD</i>	39
<i>Edit IMD Details</i>	39
<i>Initial Measurement Data Upload</i>	39
<i>Load IMDs Events Portal</i>	40
<i>Measuring Component Portal</i>	40
<i>Create Override IMD</i>	40
<i>Review IMD in VEE Ready State</i>	40
<i>Error and To Do</i>	40
<i>High Quality Check Tolerance Configuration</i>	40

<i>Batch Program for Interval IMD Estimation Process</i>	41
<i>Hours configuration for Interval IMD Estimation</i>	41
<i>Estimate IMD Interval Lifecycle</i>	41
<i>Estimate IMD Scalar Lifecycle</i>	41

■

Brief Description

Business Process: 4.2.1.1 MDM.Upload Device Measurements
Process Type: Process
Parent Process: 4.2.1 MDM. Collect and Process Measurements
Sibling Processes: 4.2.1.2 MDM.Manage VEE and VEE Exceptions, 4.2.1.3 MDM.Calculate Usage

This process gets initiated when the raw meter measurements are sent from an AMI/AMR Head-End System to MDM or created manually by an Authorized User using MDM. MDM pre-processes the initial measurements and initiates Head-End System specific processing.

Business Process Model Page 1

4.2.1.1 MDM. V2.2.0. *Upload Device Measurements. Initial Load from Head-End System*

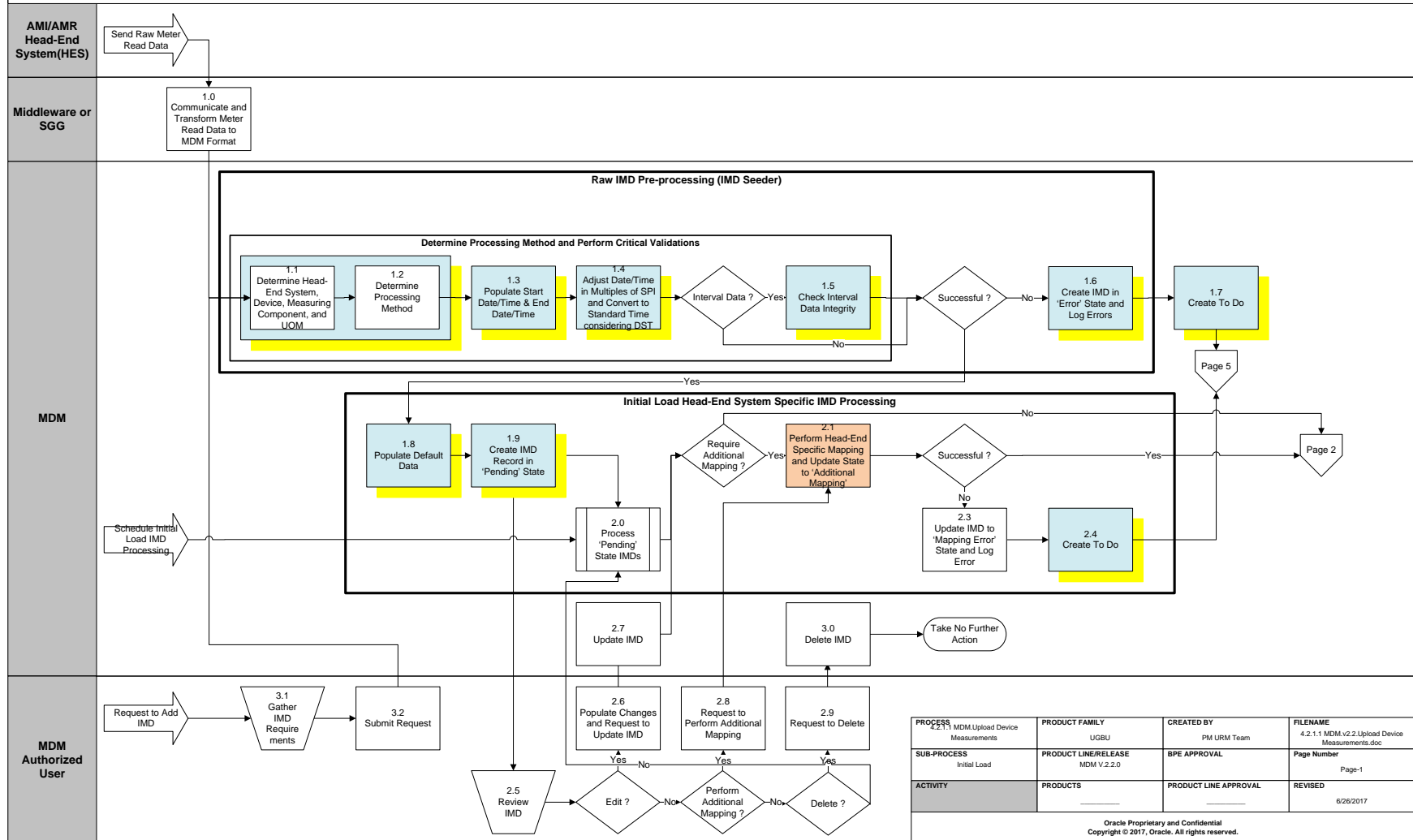

Business Process Model Page 2

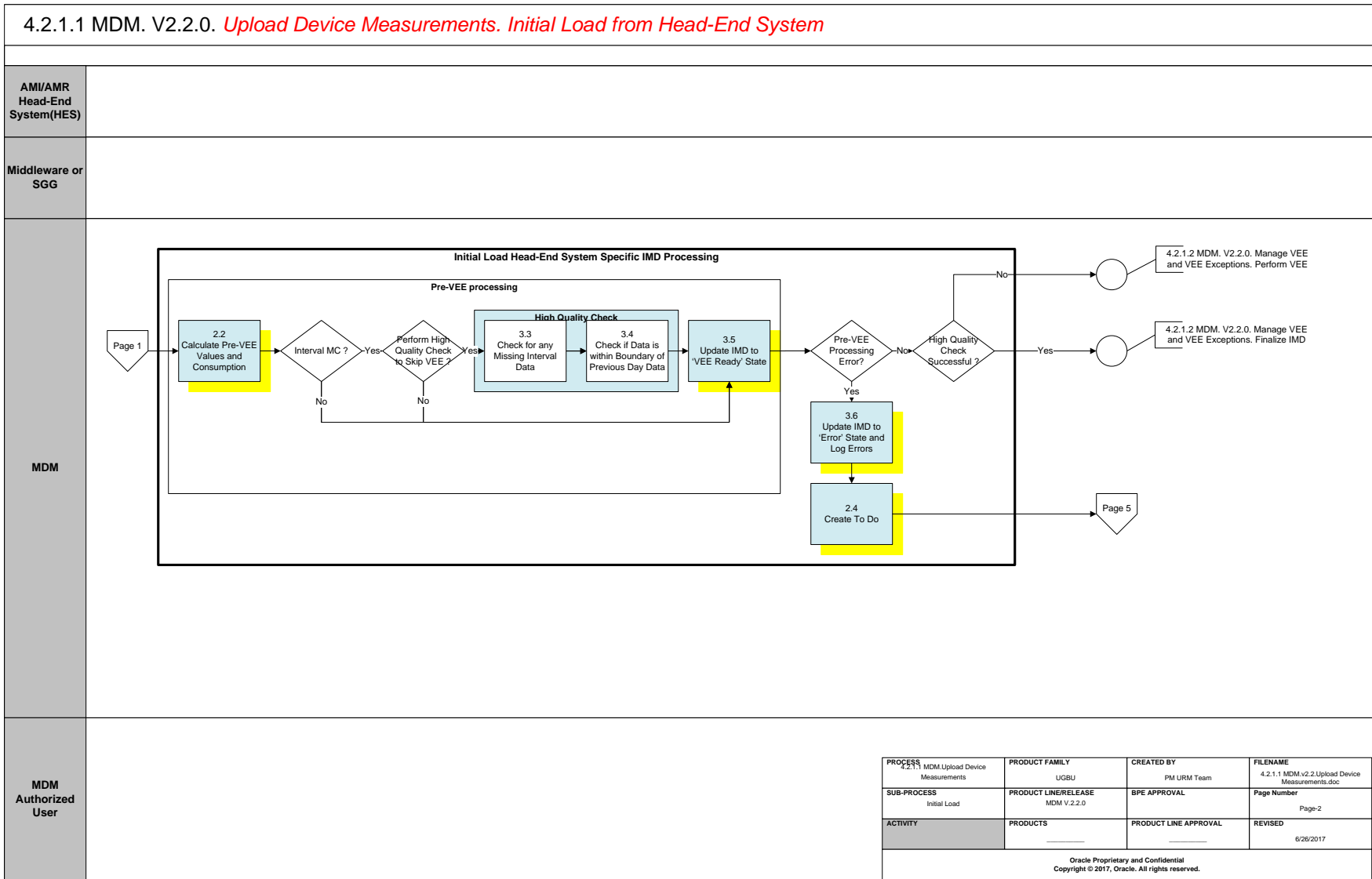

Business Process Model Page 3

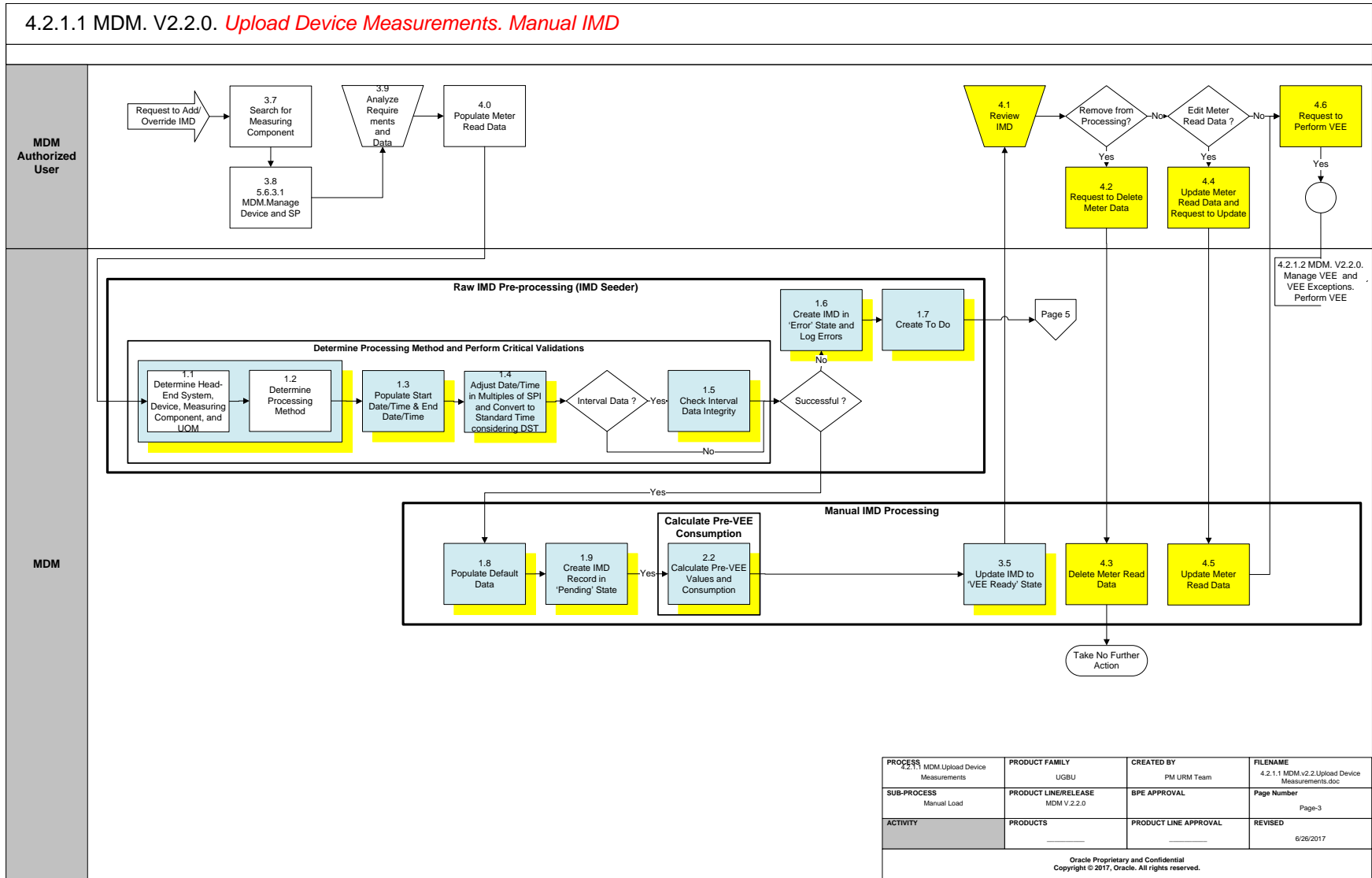

Business Process Model Page 4

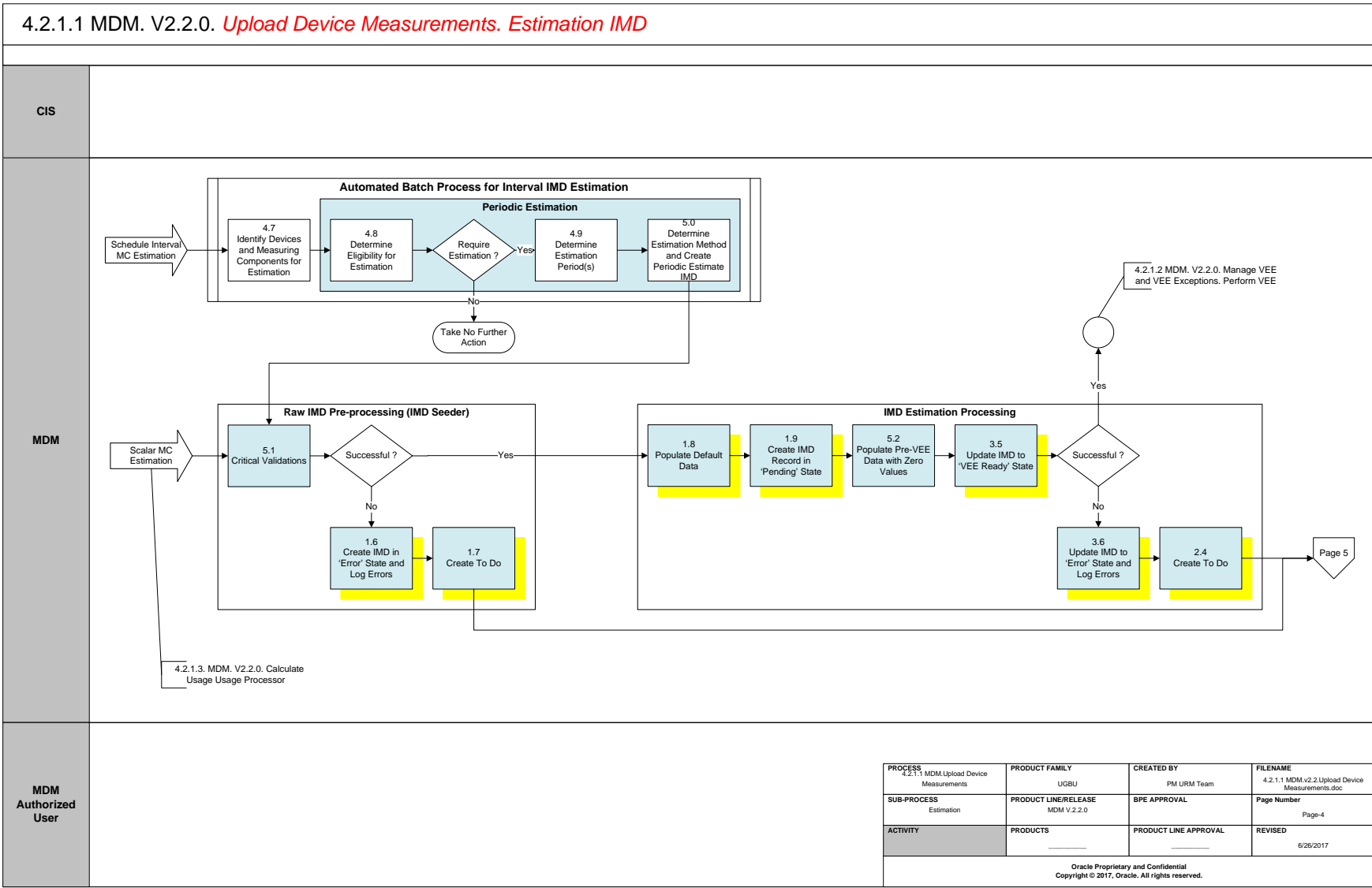

Business Process Model Page 5

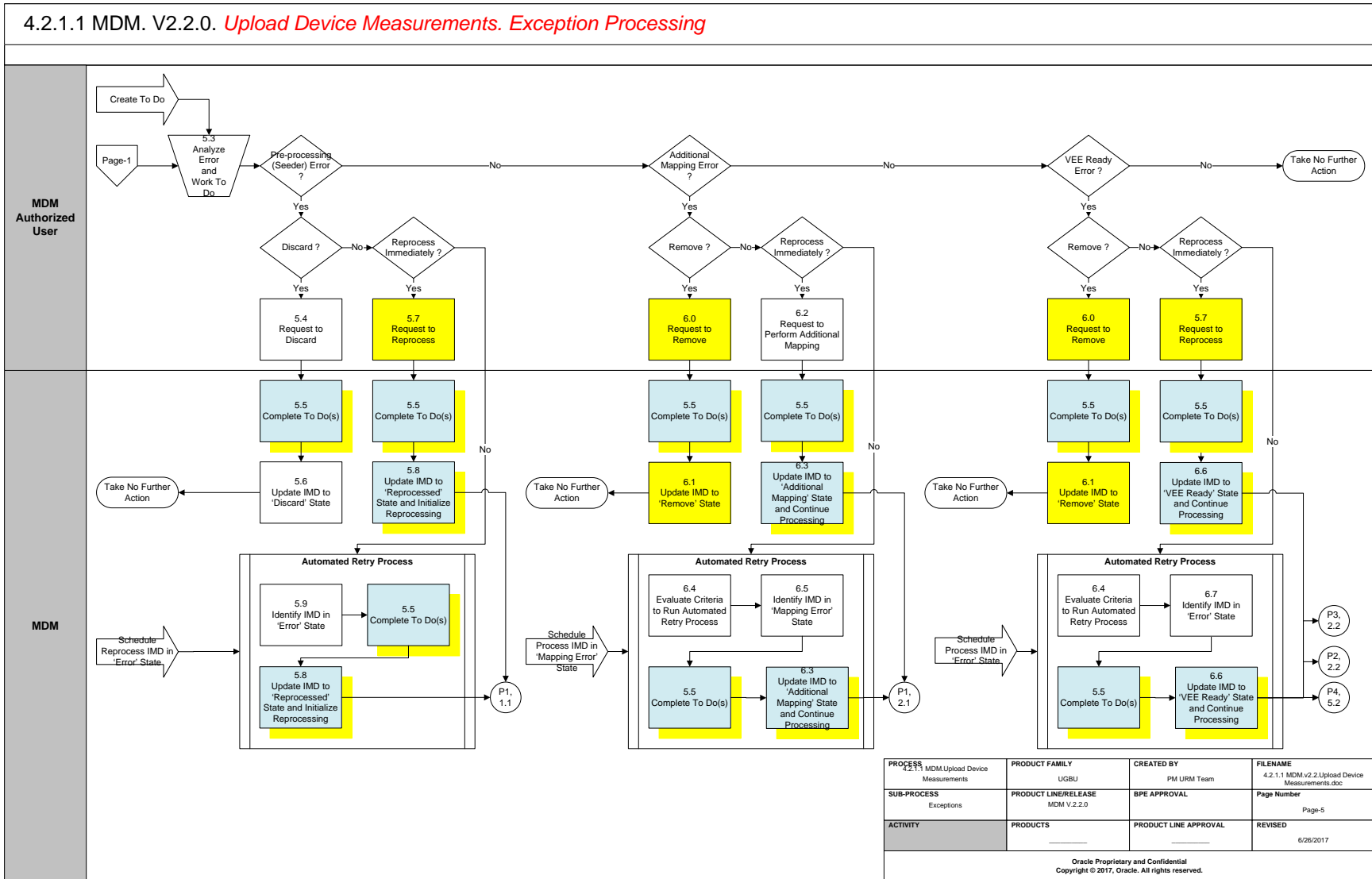

Business Process Model Page 6

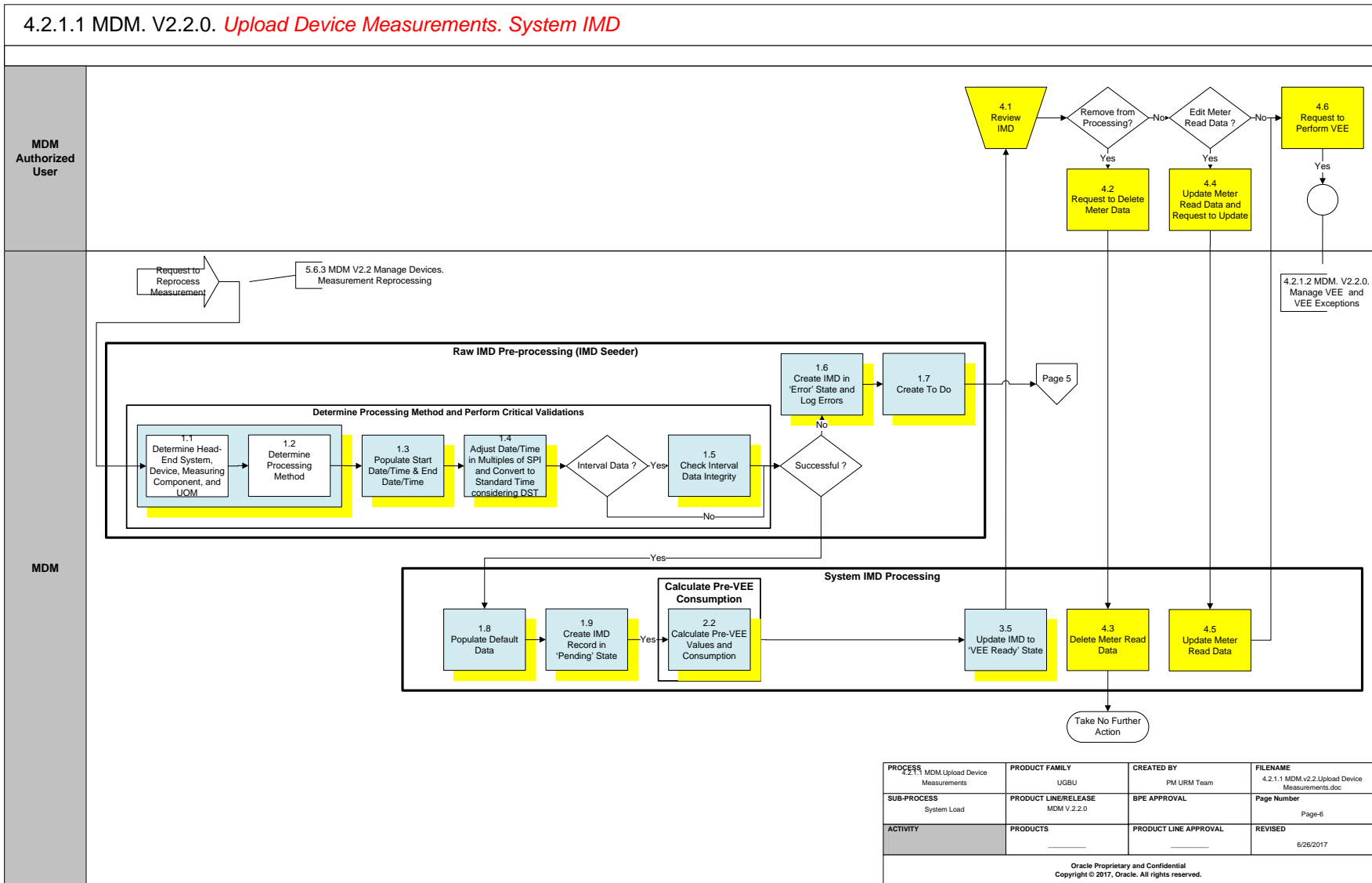

Detail Business Process Model Description

1.0 Communicate and Transform Meter Read Data to MDM Format

Actor/Role: Middleware or SGG

Description: The Middleware or Smart Grid Gateway (SGG) is responsible for communication between the MDM and the various Head-End Systems (E.g. Echelon Head-End System, Landis & Gyr Head-End System). The Middleware receives the raw meter data from the Head-End Systems, transforms, and converts it into the format compatible with the MDM. It also adds the transformed data into a JMS Queue for further processing by the MDM.

Note: There is a different set of documentation to be provided for SGG as a middleware.

Group: Raw IMD Pre-Processing (IMD Seeder)

Group: Determine Processing Method and Perform Critical Validations

1.1 Determine Head-End System, Device, Measuring Component, and UOM

Actor/Role: MDM

Description: MDM initiates pre-processing of the raw meter data received from Head-End System. The primary goal of preprocessing raw data is to perform number of critical validations. This task is the first critical validation Preprocessing. It attempts to read the raw data and determines the Head-End System (Service Provider), Device, Measuring Component, and Unit of Measure. Based on the identified Measuring Component and the Head-End System, the system determines the type of data received. If MDM is not able to determine one or more entities listed above it logs an error.

Process Plug-in enabled (Y)	Available Algorithm(s):	D1-DER-SPRMC (Determine Service Provider and Measuring Component)
Business Object (Y)	Business Object	D1-IMDSeeder
Configuration required (Y)	Entities to Configure:	Measuring Component
		Device
		Device Configuration
		Head-End System (Service Provider)

Note: It is recommended not to perform any modifications to this Algorithm as this is a standard functionality of the Product.

Group: Raw IMD Pre-Processing (IMD Seeder)**Group: Determine Processing Method and Perform Critical Validations****1.2 Determine Processing Method****Actor/Role:** MDM**Description:** MDM determines the Processing Method for the raw measurement data received. Depending on the type of data and Head End System, the Initial Load IMD or Manual IMD or Estimate IMD or System IMD is instantiated. Further it determines whether Scalar IMD or Interval processing to began.

Process Plug-in enabled (Y/N)	Available Algorithm(s):	D1-DER-SPRMC (Determine Service Provider and Measuring Component)
--------------------------------------	--------------------------------	---

Business Object (Y/N)	Business Object	D1-IMDSeeder
		Initial Load IMD (Interval)
		Initial Load IMD (Scalar)
		Manual IMD (Interval)
		Manual IMD (Scalar)
		Estimation IMD (Interval)
		Estimation IMD (Scalar)
		D1-SystemIMDScalar
		D1-SystemIMDInterval
		Head-End Specific Scalar/Interval Business Objects

Note: It is recommended not to perform any modifications to this Algorithm as this is a standard functionality of the Product.

Group: Raw IMD Pre-Processing (IMD Seeder)**Group: Determine Processing Method and Perform Critical Validations****1.3 Populate Start Date/Time & End Date/Time****Actor/Role:** MDM**Description:** MDM populates the Start Date/Time and End Date/Time. System performs this task for both Interval and Scalar types of data.

Process Plug-in enabled (Y/N)	Available Algorithm(s):	D1-VALDR-INP (Derive IMD Date/Time Values)
--------------------------------------	--------------------------------	--

Business Object (Y/N)	Business Object	D1-IMDSeeder
------------------------------	------------------------	--------------

Configuration required (Y/N)	Entities to Configure:	Measuring Component Type
-------------------------------------	-------------------------------	--

Note: It is recommended not to perform any modifications to this Algorithm as this is a standard functionality of the Product.

Group: Raw IMD Pre-Processing (IMD Seeder)

Group: Determine Processing Method and Perform Critical Validations

1.4 Adjust Date/Time in Multiples of SPI and Convert to Standard Time considering DST

Actor/Role: MDM

Description: MDM adjusts the Start Date/Time, Intervals, and End Date/Time so that they are in multiples of SPI and converts them from Local to Standard time considering the Daylight Savings Time (DST).

Process Plug-in enabled (Y/N)	Available Algorithm(s):	D1-DODTTMADJ (Perform Date/Time Adjustments and Undercount/Overcount Check)
Business Object (Y/N)	Business Object	D1-IMDSeeder
Configuration required (Y/N)	Entities to Configure:	Measuring Component Device (Incoming Data Shift) Device Configuration Service Point

Note: It is recommended not to perform any modifications to this Algorithm as this is a standard functionality of the Product.

Group: Raw IMD Pre-Processing (IMD Seeder)

Group: Determine Processing Method and Perform Critical Validations

1.5 Check Interval Data Integrity

Actor/Role: MDM

Description: MDM performs the over count and under count check for the interval data.

Process Plug-in enabled (Y/N)	Available Algorithm(s):	D1-DODTTMADJ (Perform Date/Time Adjustments and Undercount/Overcount Check)
Business Object (Y/N)	Business Object	D1-IMDSeeder
		Disable Undercount Check Disable Overcount Check

Configuration required (Y/N) **Entities to Configure:**

Disable Interval Boundaries Check

Note: It is recommended not to perform any modifications to this Algorithm as this is a standard functionality of the Product.

Group: Raw IMD Pre-Processing (IMD Seeder)

1.6 Create IMD in 'Error' State and Log Errors

Actor/Role: MDM

Description: If any error occurs during IMD pre-processing, the system creates Seeder Record in 'Error' state and logs an error.

Process Plug-in enabled (Y/N) **Available Algorithm(s):**

D1-LOG-SEEDR (Create Initial Measurement Data Seeder Log Entries)

Business Object (Y/N) **Business Object**

D1-IMDSeeder

Note: It is recommended not to perform any modifications to this Algorithm as this is a standard functionality of the Product.

Group: Raw IMD Pre-Processing (IMD Seeder)

1.7 Create To Do

Actor/Role: MDM

Description: Once the MDM system logs the errors, it creates a To Do entry for the Authorized User to allow Authorized User to review the problem and attempt to fix the error reported by system

Process Plug-in enabled (Y/N) **Available Algorithm(s):**

D1-CRE-SESTD (Create To Do for IMD Seeder)
--

Business Object (Y/N) **Business Object**

D1-IMDSeeder

Configuration required (Y/N) **Entities to Configure:**

To Do Type
To Do Role

Note: It is recommended not to perform any modifications to this Algorithm as this is a standard functionality of the Product.

Group: Initial Load Head-End System Specific IMD Processing

1.8 Populate Default Data

Actor/Role: MDM

Description: MDM populates the default data such as Date/Time and Time Zone based on the details from the raw meter data received from Head End System if they are not populated.

Process Plug-in enabled (Y/N)	Available Algorithm(s):	D1-INT-SPEC (Validate Interval Initial Measurement Data Input)
Business Object (Y/N)	Business Object	Initial Load IMD (Interval) Initial Load IMD (Scalar) Manual IMD (Interval) Manual IMD (Scalar) Estimation IMD (Interval) Estimation IMD (Scalar) D1-SystemIMDScalar D1-SystemIMDInterval Head-End Specific Scalar/Interval Business Objects

Group: Initial Load Head-End System Specific IMD Processing

1.9 Create IMD Record in 'Pending' State

Actor/Role: MDM

Description: MDM creates IMD in Pending state. Before creating, there are validation algorithms that would validate to ensure the availability of common input data such as Measuring Component Identifier, Device Identifier, and UOM to proceed forward towards IMD creation and Head-End specific processing.

Process Plug-in enabled (Y/N)	Available Algorithm(s):	D1-IMD-COMM (Validate Initial Measurement Data Common Input) F1-AT-RQJ (Transition to Default Next Status)
		Initial Load IMD (Interval) Initial Load IMD (Scalar) Manual IMD (Interval)

Business Object (Y/N)	Business Object	Manual IMD (Scalar)
		Estimation IMD (Interval)
		Estimation IMD (Scalar)
		D1-SystemIMDScalar
		D1-SystemIMDInterval
		Head-End Specific Scalar/Interval Business Objects

Group: Initial Load Head-End System Specific IMD Processing

2.0 Process 'Pending' State IMDs

Actor/Role: MDM

Description: The volume of raw meter data that Head-End System sends to MDM on regular basis is significant. Therefore in most of the cases IMDs in 'Pending' status are being processed by batch process. Business determines how often this batch process should run to process Pending IMDs.

Process Plug-in enabled (Y/N)	Available Algorithm(s):	F1-AT-RQJ (Transition to Default Next Status)
--------------------------------------	--------------------------------	--

Business Object (Y/N)	Business Object	Initial Load IMD (Interval)
		Initial Load IMD (Scalar)
		Manual IMD (Interval)
		Manual IMD (Scalar)
		Estimation IMD (Interval)
		Estimation IMD (Scalar)
		Head-End Specific Scalar/Interval Business Objects

Customizable process (Y/N)	Process Name	IMD Monitor - Physical Devices (D1-IMD)
-----------------------------------	---------------------	---

Group: Initial Load Head-End System Specific IMD Processing

2.1 Perform Head-End Specific Mapping and Update State to 'Additional Mapping'

Actor/Role: MDM

Description: This step takes place only if business identifies needs to perform additional Head End System specific mapping. Usually this step requires customization in order to satisfy MDM and Head End system specific requirements. One of the examples of such mapping is adding a prefix to a meter number to ensure it is unique.

Process Plug-in enabled (Y/N)	Available Algorithm(s):	D3-PBSCMTOCC (Interval Status Code Mapping to Condition Codes)
		D5-PBSCMTOCC (MV90 Condition Mapping with Priority)
		D5-EVCRBONSC (Event Creation Based on Status Codes)

Business Object (Y/N)	Business Object	Head-End Specific Scalar/Interval Business Objects
------------------------------	------------------------	--

Group: Initial Load Head-End System Specific IMD Processing

Group: Calculate Pre-VEE Consumption

2.2 Calculate Pre-VEE Values and Consumption

Actor/Role: MDM

Description: MDM calculates the Pre-VEE values and consumption, considering the various outages, meter multipliers, etc, and prepares data for VEE processing.

Process Plug-in enabled (Y/N)	Available Algorithm(s):	D1-PRCLINIMD (Calculate Interval Consumption and Prepare IMD)
		D1-PRCLSCIMD (Calculate and Prepare Scalar Consumption)
		D1-CSBINCPVE (Calculate Subtractive Interval Consumption and Prepare VEE)

Initial Load IMD (Interval)
D1-InitialLoadIMDSubtrInterval
Initial Load IMD (Scalar)
Manual IMD (Interval)
Manual IMD (Scalar)
Estimation IMD (Interval)
Estimation IMD (Scalar)

Business Object (Y/N)	Business Object	D1-SystemIMDScalar
		D1-SystemIMDInterval
		Head-End Specific Scalar/Interval Business Objects

Group: Initial Load Head-End System Specific IMD Processing

2.3 Update IMD to 'Mapping Error' State and Log Error

Actor/Role: MDM

Description: If any error occurs during Head-End specific additional mapping, MDM automatically updates IMD status to 'Mapping Error' and logs an error.

Process Plug-in enabled (Y/N)	Available Algorithm(s):	F1-AT-RQJ (Transition to Default Next Status)
--------------------------------------	--------------------------------	--

Business Object (Y/N)	Business Object	Initial Load IMD (Interval)
		Initial Load IMD (Scalar)
		Manual IMD (Interval)
		Manual IMD (Scalar)
		Estimation IMD (Interval)
		Estimation IMD (Scalar)
		Head-End Specific Scalar/Interval Business Objects

Group: Initial Load Head-End System Specific IMD Processing

2.4 Create To Do

Actor/Role: MDM

Description: Once the MDM system logs the errors, it creates a To Do entry for the Authorized User to allow Authorized User to review the problem and attempt to fix the error reported by system

Process Plug-in enabled (Y/N)	Available Algorithm(s):	D1-CRE-TDNVE (Create IMD To Do for Error States)
--------------------------------------	--------------------------------	--

Initial Load IMD (Interval)
Initial Load IMD (Scalar)
Manual IMD (Interval)

Business Object (Y/N)	Business Object	Manual IMD (Scalar)
		Estimation IMD (Interval)
		Estimation IMD (Scalar)
		Head-End Specific Scalar/Interval Business Objects

Configuration required (Y/N)	Entities to Configure:	To Do Type
		To Do Role

[2.5 Review IMD](#)

Actor/Role: MDM Authorized User

Description: When the IMD Record is created in Pending State, the MDM Authorized User has the option to review and analyze IMD before it will be processed by background batch process using [Review Pending State IMD](#) page.

[2.6 Populate Changes and Request to Update IMD](#)

Actor/Role: MDM Authorized User

Description: If Authorized User decides that pending IMD requires modifications, the Authorized User can edit the details using [Edit IMD Details](#) page.

[2.7 Update IMD](#)

Actor/Role: MDM

Description: MDM updates the IMD record.

Process Plug-in enabled (Y/N)	Available Algorithm(s):	D1-AUD-QTYUE (Audit IMD Quantity Changes and Set User-Edited Flag)
--------------------------------------	--------------------------------	---

Initial Load IMD (Interval)
Initial Load IMD (Scalar)
Manual IMD (Interval)
Manual IMD (Scalar)
Estimation IMD (Interval)

Business Object (Y/N)**Business Object**[Estimation IMD \(Scalar\)](#)

Head-End Specific Scalar/Interval Business Objects

2.8 Request to Perform Additional Mapping

Actor/Role: MDM Authorized User**Description:** If Authorized User determines that pending IMD should be processes immediately and business requires performing Additional Head End system mapping as a next step, then Authorized User requests to [perform additional mapping](#).

2.9 Request to Delete

Actor/Role: MDM Authorized User**Description:** If Authorized User determines that pending IMD must be deleted, MDM Authorized User has the option to manually invoke a request in MDM to [delete the IMD Record](#).

3.0 Delete IMD

Actor/Role: MDM**Description:** MDM deletes the IMD Record in 'Pending' state based on the request to delete made by MDM Authorized User.

Note: Once a record is deleted it is permanently removed from the system and it cannot be retrieved. Further, in general, option to delete IMD is enabled for all states before VEE, for all types of IMDs.

3.1 Gather IMD Requirements

Actor/Role: MDM Authorized User**Description:** When creating Initial Measurements online, the Authorized User gathers all the required attributes for adding an initial measurement. The IMD information such as Measuring Component, Start and Stop Date and Time, Consumption, etc. is gathered.**Business Object (Y/N)****Business Object**

D1-InitialLoadIMDInterval

D1-InitialLoadIMDScalar

Measuring Component

Device

Configuration required (Y/N)	Entities to Configure:	Start and Stop Date and Time
		Consumption for Scalar IMD
		Intervals and respective data for Interval IMD

3.2 Submit Request

Actor/Role: MDM Authorized User

Description: MDM Authorized User adds Initial Measurement Data (IMD) in the MDM Application:

- by using the [Initial Measurement Upload Portal](#) or
- load online by supplying an XML document using [Load IMDs/Events \(XML\)](#) portal or
- by using 360 view (selecting either “Create New reading” or “Create Override” option)

MDM performs an audit of the IMD added.

Process Plug-in enabled (Y/N)	Available Algorithm(s):	D1-AUD-QTYUE (Audit IMD Quantity Changes and Set User-Edited Flag)
--------------------------------------	--------------------------------	--

Business Object (Y/N)	Business Object	D1-InitialLoadIMDInterval
		D1-InitialLoadIMDScalar

Configuration required (Y/N)	Entities to Configure:	Measuring Component
		Device
		Start and End Date and Time
		Consumption for Scalar IMD
		Intervals and respective data for Interval IMD

Group: Initial Load Head-End System Specific IMD Processing

Group: High Quality Check

3.3 Check for any Missing Interval Data

Actor/Role: MDM

Description: MDM checks if there are any missing intervals in the current IMD in process.

Process Plug-in enabled (Y/N)	Available Algorithm(s):	D1-HIGHQUALV (High Quality Check - Vector Band Based)
--------------------------------------	--------------------------------	---

Business Object (Y/N)	Business Object	D1-InitialLoadIMDInterval
------------------------------	------------------------	---------------------------

Group: Initial Load Head-End System Specific IMD Processing

Group: High Quality Check

3.4 Check if data is within boundary of previous day data

Actor/Role: MDM

Description: MDM checks if the Interval data in the current IMD is within the boundary (pre-defined [tolerance levels](#)) of previous day's corresponding interval data.

Process Plug-in enabled (Y/N)	Available Algorithm(s):	D1-HIGHQUALV (High Quality Check - Vector Band Based)
--------------------------------------	--------------------------------	---

Business Object (Y/N)	Business Object	D1-InitialLoadIMDInterval
------------------------------	------------------------	---------------------------

Configuration required (Y/N)	Entities to Configure:	High Tolerance Low Tolerance
-------------------------------------	-------------------------------	---------------------------------

Group: Initial Load Head-End System Specific IMD Processing

3.5 Update IMD to 'VEE Ready' State

Actor/Role: MDM

Description: MDM prepares the data ready for VEE and updates IMD status to VEE Ready. For Initial Load, during this state, if the High Quality Check has been successful, then VEE process will be skipped and the IMD would directly proceed towards Normalization and Finalization. However if the High Quality Check fails, the IMD will undergo its regular VEE Processing.

Process Plug-in enabled (Y/N)	Available Algorithm(s):	F1-AT-RQJ (Transition to Default Next Status)
--------------------------------------	--------------------------------	--

Initial Load IMD (Interval)
Initial Load IMD (Scalar)
Manual IMD (Interval)

Business Object (Y/N)	Business Object
	Manual IMD (Scalar)
	Estimation IMD (Interval)
	Estimation IMD (Scalar)
	D1-SystemIMDScalar
	D1-SystemIMDInterval
	Calculate Pre-VEE Consumption

Group: Initial Load Head-End System Specific IMD Processing

3.6 Update IMD to 'Error' State and Log Errors

Actor/Role: MDM

Description: If any error occurs while MDM prepares data for VEE, MDM automatically updates IMD status to 'Error' state and logs an error.

Process Plug-in enabled (Y/N)	Available Algorithm(s):
	F1-AT-RQJ (Transition to Default Next Status)

Business Object (Y/N)	Business Object
	Initial Load IMD (Interval)
	Initial Load IMD (Scalar)
	Manual IMD (Interval)
	Manual IMD (Scalar)
	Estimation IMD (Interval)
	Estimation IMD (Scalar)
	Head-End Specific Scalar/Interval Business Objects

3.7 Search for Measuring Component

Actor/Role: MDM Authorized User

Description: MDM Authorized User searches for the Measuring Component to create a Manual IMD.

Business Object (Y/N)	Business Object
	D1-InitialLoadIMDInterval
	D1-InitialLoadIMDScalar
	D1-Manual IMD (Interval)
	D1-Manual IMD (Scalar)
	Measuring Component

Configuration required (Y/N) **Entities to Configure:**

Device

[3.8](#) 5.6.3.1 Manage Device and SP

Actor/Role: MDM User

Description: If required, Authorized User creates or updates Device data and Service Point data in this step. Please refer to process 5.6.3.1 Manage Device SP for further information about this.

[3.9](#) Analyze Requirements and Data

Actor/Role: MDM Authorized User

Description: Sometimes Authorized User needs to create a new IMD manually. MDM Authorized User analyzes requirements and various data before creating new IMD manually.

[4.0](#) Populate Meter Read Data

Actor/Role: MDM Authorized User

Description: MDM Authorized User populates the meter data. To create a new IMD, Authorized User uses [Create/Override](#) screen to populate content.

Process Plug-in enabled (Y/N) **Available Algorithm(s):**

D1-AUD-QTYUE (Audit IMD Quantity Changes and Set User-Edited Flag)
--

Business Object (Y/N) **Business Object**

D1-InitialLoadIMDInterval
D1-InitialLoadIMDScalar
D1-Manual IMD (Interval)
D1-Manual IMD (Scalar)

Configuration required (Y/N) **Entities to Configure:**

Measuring Component
Start and End Date and Time
Consumption
Condition (E.g. Office Estimate)
Conversion Method (E.g. Use Straight Line)
Profile Factor

4.1 Review IMD

Actor/Role: MDM Authorized User

Description: When the IMD Record is created in 'VEE Ready' State, the MDM Authorized User has the option to review and analyze IMD before it will be processed by background batch process using [Review IMD in VEE Ready State](#) page.

4.2 Request to Delete Meter Data

Actor/Role: MDM Authorized User

Description: If Authorized User determines that IMD Record in 'VEE Ready' state is incorrect or has been created by mistake, MDM Authorized User manually invokes a [request in MDM to delete the IMD Record](#).

Group: Manual IMD Processing

4.3 Delete Meter Read Data

Actor/Role: MDM

Description: MDM deletes the IMD Record in 'VEE Ready' state based on the request to delete made by MDM Authorized User.

Note: Once a record is deleted it is permanently removed from the system and it cannot be retrieved.

4.4 Update Meter Read Data and Request to Update

Actor/Role: MDM Authorized User

Description: If Authorized User decides that IMD requires modifications, the Authorized User updates it using [Review IMD in VEE Ready State Page](#).

Group: Manual IMD Processing

4.5 Update Meter Read Data

Actor/Role: MDM

Description: MDM updates the IMD Record for any modifications made to it.

4.6 Request to Perform VEE**Actor/Role:** MDM Authorized User**Description:** If Authorized User is satisfied with review results and cannot detect any problems, Authorized User [requests to perform VEE](#). Please refer to process 4.2.1.2 MDM. V2.2.0. Manage VEE and VEE Exceptions for more details.**Group: Automated Batch Process for Interval IMD Estimation****4.7 Identify Devices & Measuring Components for Estimation****Actor/Role:** MDM**Description:** A batch process (D1-SMMTR) invokes the Estimation process for Interval Data Devices with Periodic Estimation algorithm plugged-in on Active State of the Device.

Business Object (Y/N)	Business Object	D1-InitialLoadIMDInterval D1-SmartMeter
Configuration required (Y/N)	Entities to Configure:	Device Type in Batch Process
Customizable process (Y/N)	Process Name	Smart Meter State Monitor Process (D1-SMMTR)

Group: Automated Batch Process for Interval IMD Estimation**Group: Periodic Estimation****4.8 Determine Eligibility for Estimation****Actor/Role:** MDM**Description:** MDM Analyzes and determines Measuring Components on which estimation methods can run. Further, MDM checks if the Measuring Component is due and eligible for estimation based on [configured parameters](#). It first checks if the latest measurement date/time is later than the process date/time minus Hours before Estimation and if true, it will not proceed with estimation assuming it is still not right time for estimation. Else, it checks if there are minimum number of Hours to estimate. If true, it will proceed towards estimation.

Process Plug-in enabled (Y/N)	Available Algorithm(s):	D1-PERESTM (Periodic Estimation)
--------------------------------------	--------------------------------	----------------------------------

Business Object (Y/N)	Business Object	<input type="text" value="D1-SmartMeter"/>
------------------------------	------------------------	--

Configuration required (Y/N)	Entities to Configure:	<input type="text" value="Hours before Estimation"/>
		<input type="text" value="No. of Hours to Estimate"/>

Group: Automated Batch Process for Interval IMD Estimation**Group: Periodic Estimation****4.9 Determine Estimation Period(s)****Actor/Role:** MDM**Description:** MDM analyses the existing measurements for the MC and any under-process Interval IMD for any overlapping period with respect to current estimation period. Based on the overlapping periods of existing measurements and under-process interval IMD, it determines the number of period(s) of estimation and also the start date/time and end date/time for these period(s) of estimation.

Process Plug-in enabled (Y/N)	Available Algorithm(s):	<input type="text" value="D1-PERESTM (Periodic Estimation)"/>
--------------------------------------	--------------------------------	---

Business Object (Y/N)	Business Object	<input type="text" value="D1-SmartMeter"/>
------------------------------	------------------------	--

Group: Automated Batch Process for Interval IMD Estimation**Group: Periodic Estimation****5.0 Determine Estimation Method and Initiate to Create Periodic Estimate IMD****Actor/Role:** MDM**Description:** MDM invokes the Estimate creation through Seeder preprocessing passing on the "Estimation" look up value.

Process Plug-in enabled (Y/N)	Available Algorithm(s):	<input type="text" value="D1-PERESTM (Periodic Estimation)"/>
--------------------------------------	--------------------------------	---

Business Object (Y/N)	Business Object	<input type="text" value="D1-SmartMeter"/>
		<input type="text" value="D1-IMDSeeder"/>

Group: Raw IMD Pre-processing (IMD Seeder)

5.1 Critical Validations

Actor/Role: MDM

Description: MDM performs the critical validations for the estimate IMD as part of seeder pre-processing. However, it should be noted, that unlike the Initial Load IMD Seeder pre-processing, this is not a full fledged pre-processing.

Business Object (Y/N)	Business Object	D1-IMDSeeder
------------------------------	------------------------	--------------

Group: IMD Estimation Processing

5.2 Populate Pre-VEE Data with Zero values

Actor/Role: MDM

Description: MDM populates Pre-VEE data for the Interval(s) with 'Zero' values. The actual values would be estimated during the VEE processing.

Process Plug-in enabled (Y/N)	Available Algorithm(s):	D1-CRMIIMDPR (Populate IMD Pre-VEE / Post-VEE group with 0 Value Intervals)
--------------------------------------	--------------------------------	---

Business Object (Y/N)	Business Object	D1-EstimationIMD (Interval)
		D1-Estimation IMD (Scalar)

Note: There is no specific Head-End Specific Mapping and Calculate Consumption Logic for Estimate IMD Processing.

5.3 Analyze Error and Work To Do

Actor/Role: MDM Authorized User

Description: MDM Authorized User [analyzes the error logged and respective To Do created](#) to determine the corrective action. User performs work to resolve the error.

D1-IMDSeeder
D1-InitialLoadIMDInterval
D1-InitialLoadIMDScalar
D1-Manual IMD (Interval)
D1-Manual IMD (Scalar)

Business Object (Y/N)

Business Object

D1-Estimation IMD (Interval)
D1-Estimation IMD (Scalar)
Head-End Specific Scalar/Interval Business Objects

5.4 Request to Discard

Actor/Role: MDM Authorized User

Description: When the seeder is in 'Error' state and when MDM Authorized User decides that the IMD cannot be used, can manually make request to discard it.

Business Object (Y/N)

Business Object

D1-IMDSeeder

5.5 Complete To Do(s)

Actor/Role: MDM

Description: MDM finds all non-completed To Do entries and completes them before reprocessing.

Process Plug-in enabled (Y/N)

Available Algorithm(s):

D1-COMP-TD (Complete To Do Entries for Initial Measurement Data)
--

5.6 Update IMD to 'Discard' State

Actor/Role: MDM

Description: MDM transitions IMD seeder object to 'Discard' status indicating that it cannot be used further. However it remains in the system.

Business Object (Y/N)

Business Object

D1-IMDSeeder

5.7 Request to Reprocess

Actor/Role: MDM Authorized User

Description: When the seeder is in 'Error' state and MDM Authorized User has corrected the error, can manually make request to reprocess the seeder.

Process Plug-in enabled (Y/N)	Available Algorithm(s):	F1-AT-RQJ (Transition to Default Next Status)
Business Object (Y/N)	Business Object	D1-IMDSeeder

[5.8](#) Update IMD to 'Reprocessed' State and Initialize Reprocessing

Actor/Role: MDM

Description: MDM transition the seeder to 'Reprocessed' state and initializes reprocessing.

Process Plug-in enabled (Y/N)	Available Algorithm(s):	D1-CRE-IMDSD (Attempt to Reprocess Seeder Initial Measurement)
Business Object (Y/N)	Business Object	D1-IMDSeeder

Group: Automated Retry Process

[5.9](#) Identify IMD in 'Error' State

Actor/Role: MDM

Description: Batch Process continuously monitors to identify the IMD seeder in 'Error' state. Currently, the Batch process used for this is Generic IMD Monitor -IMD Seeder (D1-GNIMD).

Process Plug-in enabled (Y/N)	Available Algorithm(s):	DM_IMD (IMD Monitor - Standard AutoTransition)
Business Object (Y/N)	Business Object	D1-IMDSeeder
Customizable process (Y/N)	Process Name	Generic IMD Monitor - IMD Seeder (D1-GNIMD)

[6.0](#) Request to Remove

Actor/Role: MDM Authorized User

Description: When the IMD is in 'Error' state and when Authorized User decides that the IMD can be removed, Authorized User can manually make [request to remove](#) it.

Business Object (Y/N)**Business Object**

D1-InitialLoadIMDInterval
D1-InitialLoadIMDScalar
Manual IMD (Interval)
Manual IMD (Scalar)
Head-End Specific Scalar/Interval Business Objects

6.1 Update IMD to 'Remove' State**Actor/Role:** MDM**Description:** MDM updates IMD to 'Remove' state.**Process Plug-in enabled (Y/N)****Available Algorithm(s):**

F1-AT-RQJ (Transition to Default Next Status)
--

Business Object (Y/N)**Business Object**

D1-InitialLoadIMDInterval
D1-InitialLoadIMDScalar
Manual IMD (Interval)
Manual IMD (Scalar)
Head-End Specific Scalar/Interval Business Objects

6.2 Request to Perform Additional Mapping**Actor/Role:** MDM**Description:** When the IMD is in 'Mapping Error' state and when Authorized User decides to perform Additional Mapping after resolving the error, Authorized User can manually make a request to [perform Additional Mapping](#). One example of such an error is an event of wrong entry during system configuration.**Business Object (Y/N)****Business Object**

D1-InitialLoadIMDInterval
D1-InitialLoadIMDScalar
Manual IMD (Interval)
Manual IMD (Scalar)
Head-End Specific Scalar/Interval Business Objects

6.3 Update IMD to 'Additional Mapping' State and Continue Processing

Actor/Role: MDM

Description: MDM transition the IMD in 'Mapping Error' state to 'Additional Mapping' and initiates processing.

Process Plug-in enabled (Y/N) **Available Algorithm(s):**

F1-AT-RQJ (Transition to Default Next Status)
--

Business Object (Y/N) **Business Object**

D1-InitialLoadIMDInterval
D1-InitialLoadIMDScalar
Manual IMD (Interval)
Manual IMD (Scalar)
Head-End Specific Scalar/Interval Business Objects

Group: Automated Retry Process

6.4 Evaluate Criteria to Run Automated Retry Process

Actor/Role: MDM

Description: Batch process is configured for this automated retry process. Batch parameters govern whether the processing is further restricted by batch code, business object, status, etc. Currently, the Batch process used for reprocessing the IMDs in 'Mapping Error State' is Generic IMD Monitor - IMD Seeder (D1-GNIMD). The Batch process used for reprocessing the IMDs in 'VEE Error State' is IMD Monitor - Physical Devices. This batch process invokes monitoring rules associated with the current state of IMD.

Process Plug-in enabled (Y/N) **Available Algorithm(s):**

D1-IMD-RETRY (Retry Initial Measurement Data Processing)
--

Business Object (Y/N) **Business Object**

D1-InitialLoadIMDInterval
D1-InitialLoadIMDScalar
Manual IMD (Interval)
Manual IMD (Scalar)
Head-End Specific Scalar/Interval Business Objects

Customizable process (Y/N) **Process Name**

Generic IMD Monitor - IMD Seeder (D1-GNIMD)
IMD Monitor - Physical Devices (D1-IMD)

Group: Automated Retry Process

6.5 Identify IMD in 'Mapping Error' State

Actor/Role: MDM

Description: Batch process identifies IMD record in 'Mapping Error' and attempts to re-process the IMDs.

Process Plug-in enabled (Y/N)	Available Algorithm(s):	D1-IMD-RETRY (Retry Initial Measurement Data Processing)
Business Object (Y/N)	Business Object	D1-InitialLoadIMDInterval D1-InitialLoadIMDScalar Manual IMD (Interval) Manual IMD (Scalar)
Customizable process (Y/N)	Process Name	Generic IMD Monitor - IMD Seeder (D1-GNIMD)

6.6 Update IMD to 'VEE Ready' State and Continue Processing

Actor/Role: MDM

Description: MDM transition the IMD in 'Error' state to 'VEE Ready' and initiates processing.

Process Plug-in enabled (Y/N)	Available Algorithm(s):	F1-AT-RQJ (Transition to Default Next Status)
Business Object (Y/N)	Business Object	D1-InitialLoadIMDInterval D1-InitialLoadIMDScalar Manual IMD (Interval) Manual IMD (Scalar)

Group: Automated Retry Process

6.7 Identify IMD in 'Error' State

Actor/Role: MDM

Description: Batch process identifies IMD record in 'Error' and initiates re-processing last step ended in error.

Process Plug-in enabled (Y/N)	Available Algorithm(s):	D1-IMD-RETRY (Retry Initial Measurement Data Processing)
Business Object (Y/N)	Business Object	D1-InitialLoadIMDInterval D1-InitialLoadIMDScalar Manual IMD (Interval) Manual IMD (Scalar) Head-End Specific Scalar/Interval Business Objects
Customizable process (Y/N)	Process Name	IMD Monitor - Physical Devices (D1-IMD)

Test Documentation related to the Current Process

ID	Document Name	Test Type

Document Control

Change Record

Date	Author	Version	Change Reference
9/13/2011	Srinivas Rao Kanteti	1	Initial Draft
4/6/2015	Srinivas Rao Kanteti	2	Revised Version
11/17/2015	Walter Wolanski		Review and updates
11/18/2015	Galina Polonsky		Review, Approve

Attachments

Dictionary



Dictionary.doc

IMD Seeder Lifecycle



IMD Seeder
Lifecycle.doc

Initial Load IMD Interval Lifecycle



Initial Load IMD
Interval Lifecycle.doc

Initial Load IMD Scalar Lifecycle



Initial Load IMD
Scalar Lifecycle.doc

Manual IMD Interval Lifecycle



Manual IMD Interval
Lifecycle.doc

Manual IMD Scalar Lifecycle



Manual IMD Scalar
Lifecycle.doc

Measuring Component Portal



Measuring
Component Type.doc

Device Configuration Portal - Incoming Data Shift



Device
Configuration_Incomi

Review Pending State IMD



Review Pending
State IMD.doc

Edit IMD Details



Edit IMD Details.doc

Initial Measurement Data Upload



Initial Measurement
Data Upload.doc

Load IMDs Events Portal



Load IMDs Events
Portal.doc

Measuring Component Portal



Measuring
Component Portal.do

Create Override IMD



Create Override
IMD.doc

Review IMD in VEE Ready State



Review IMD in VEE
Ready State.doc

Error and To Do



Error and To Do.doc

High Quality Check Tolerance Configuration



High Quality Check
Tolerance Configurati

Batch Program for Interval IMD Estimation Process



Batch Program for
Interval IMD Estimatic

Hours configuration for Interval IMD Estimation



Hours configuration
for Interval IMD Estin

Estimate IMD Interval Lifecycle



Estimate IMD
Interval Lifecycle.doc

Estimate IMD Scalar Lifecycle



Estimate IMD Scalar
Lifecycle.doc